



	Installation: Remote Keypad
	Installation: Console de visualisation
	Installazione: Tastiera remota
	Installation: Fernbedienung
	Instalación: Operador Remoto

Ref. 4898 - 2011.11 / a
0477-0020-02



WARNING: Remove mains and control voltage from the soft starter before attaching or removing accessories.
AVERTISSEMENT: Supprimer la tension réseau et de commande du démarreur progressif avant de monter ou de retirer des accessoires.
AVVERTENZA: Togliere dall'avviatore statico la tensione di rete e la tensione di controllo prima di collegare o rimuovere accessori.
WARNUNG: Trennen Sie die Haupt- und die Steuerspannung vom Softstarter, bevor Sie Zubehör anschließen oder abtrennen.
ADVERTENCIA: Quitar la tensión principal o de control del arrancador suave antes de conectar o desconectar accesorios.

Installation / Installation / Installazione / Installation / Instalación

1. Remove control power and mains supply from the soft starter.
 2. Attach the module to the soft starter as illustrated.
1. Débrancher l'alimentation du réseau et de commande du démarreur progressif.
 2. Fixer le module au démarreur comme illustré.
1. Togliere l'alimentazione al controllo e la tensione di rete all'avviatore statico.
 2. Attaccare il modulo all'avviatore statico come mostrato in figura.
1. Trennen Sie die Haupt- und die Steuerspannung vom Softstarter.
 2. Befestigen Sie das Modul am Softstarter entsprechend der Abbildung.
1. Quitar la tensión de control y la alimentación principal del arrancador suave.
 2. Conectar el módulo al arrancador suave tal y como se muestra.

Connection / Connexion / Collegamenti / Anschluss / Conexión

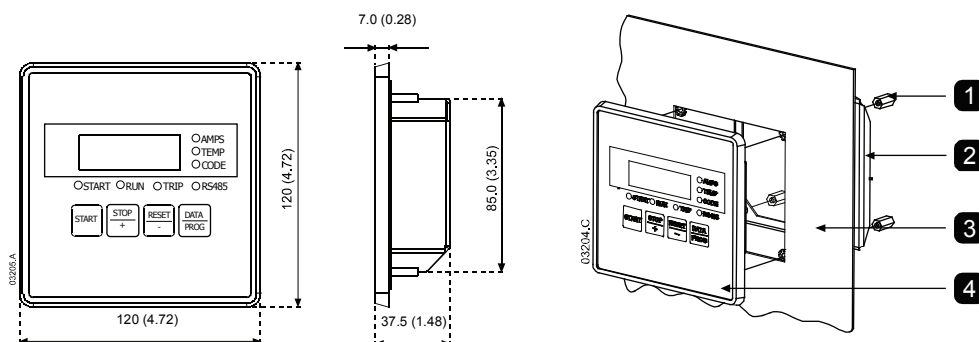

1	Fasteners (x4) Ecrous (x4) Elementi di fissaggio (x4) Schrauben (x4) Tornillos (x4)
2	Mounting bracket Bride de fixation Staffa di montaggio Montage Soporte de montaje
3	Universal panel cutout (92 mm x 92 mm) Découpe dans le panneau universel (92 mm x 92 mm) Apertura del pannello universale (92 mm x 92 mm) Ausschnitt (92 mm x 92 mm) Hueco de panel universal (92 mm x 92 mm)
4	Remote Keypad Console de visualisation Tastiera remota Fernbedienung Operador Remoto

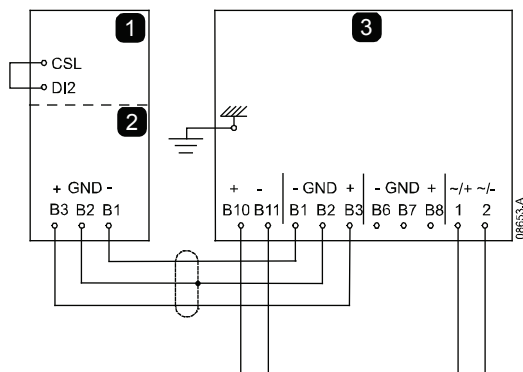

1	Digistart CS/D2
2	Remote Keypad Module - RS485 serial port Module Console de visualisation - Port série RS485 Modulo del Tastiera remota - Porta seriale RS485 Fernbedienung Modul - serieller Anschluss RS485 Módulo del Operador Remoto - puerto serie RS485
3	<p>Remote Keypad B10, B11: 4-20 mA analog output (motor current) B1, B2, B3: RS485 connection to starter/module B6, B7, B8: RS485 connection to network 1, 2: power supply (18 to 30 Vac/Vdc)</p> <p>Console de visualisation B10 B11 : sortie analogique 4-20 mA (courant moteur) B1, B2, B3 : connexion RS485 vers le démarreur/module B6, B7, B8 : connexion RS485 vers le réseau 1, 2 : alimentation (18 à 30 Vac/Vdc)</p> <p>Tastiera remota B10 B11 uscita analogica 4-20 mA (corrente motore) B1, B2, B3: collegamento RS485 ad avviatore/module B6, B7, B8: collegamento RS485 alla rete 1, 2: alimentatore (18 a 30 Vac/Vdc)</p> <p>Fernbedienung B10, B11: 4 bis 20 mA Analogausgang (Motorstrom) B1, B2, B3: RS485 Serieller Starterport (Softstarter-Anschluss) B6, B7, B8: serieller RS485-Netzwerkanschluss (Zubehör) 1, 2: Spannung (18 bis 30 Vac/Vdc)</p> <p>Operador Remoto B10, B11: salida analógica 4-20 mA (intensidad del motor) B1, B2, B3: Conexión RS485 al arrancador/módulo B6, B7, B8: Conexión a red RS485 1, 2: Alimentación (18 a 30 Vac/Vdc)</p>

For the Remote Keypad to accept serial commands, a link must be fitted across terminals CSL DI2 on Digistart CS/D2 starters.

Pour que la Console de visualisation accepte des commandes, une liaison doit être établie entre les bornes CSL DI2 sur les démarreurs Digistart CS/D2.

Affinché Tastiera remota possa accettare comandi seriali, è necessario collegare tra loro i terminali CSL DI2 sui avviatori Digistart CS/D2.

Damit die Fernbedienung serielle Befehle annehmen kann, muss eine Verbindung zwischen den Klemmen CSL DI2 am Digistart CS/D2 hergestellt werden.

Para que el Operador Remoto acepte órdenes por comunicaciones serie, se debe instalar una conexión a través de los terminales CSL DI2 en los arrancadores Digistart CS/D2.

For the latest manuals and software, please visit our website.

Pour obtenir la dernière version des notices et du logiciel, consulter notre site Web.

Per le versioni più recenti dei manuali e del software, visitare il nostro sito.

Die aktuellen Handbücher und die aktuelle Software finden Sie auf unsere Website.

Para obtener los manuales y software más recientes, por favor visite nuestro sitio web.



710-08857-00B