

Dynamic Braking Resistors

Dynamic Braking (DB)

The DC bus voltage level of an AC drive increases while the motor is re-generating (i.e. ramping to a stop). Dynamic braking resistors provide a means of rapidly stopping a rotating motor and load while maintaining an acceptable bus voltage level. The kinetic energy stored in the spinning mass is converted into electrical energy and quickly dissipated as heat through a resistor.

Dynamic Braking for AC Drives

AC drives provide a constant torque stopping profile when a dynamic brake resistor is applied across the DC bus circuit. Dynamic braking can be employed under a stop command or anytime a decrease in motor speed is commanded, provided the AC drive is enabled and programmed for ramp stop (fast ramp mode).

Two types of dynamic braking kits are available for Control Techniques' AC Drives. The E-stop duty kits are rated for light start/stop or deceleration duty cycles.

The cyclic duty kits are intended for heavy duty applications that need the capability to dissipate regenerated energy on a more continuous or repetitive basis such as downhill conveyors, hoists, feeders and dynamometers.



Galvanized NEMA 1 with normally closed thermostat

E-Stop Duty

E-stop duty DB resistors are designed for absorbing energy generated by infrequent motor stops or deceleration.

These kits are designed to meet or exceed NEMA standard 7-15-1970, which states "DB resistors will not exceed their rated temperature rise when the drive is braked from maximum speed to standstill three times in rapid succession with a load inertia equal to or less than the motor inertia." They are designed to provide 150% braking torque for 1800 rpm base speed motors.

DB Resistors for AC Drives

Unidrive M drives are equipped with built-in dynamic braking transistors. Simply select the proper braking resistor needed for the size of drive and duty cycle. Other mounting arrangements and enclosures are available on request.

The brake circuit must include an external thermal protection device connected (as shown in the circuit diagram) unless the resistor has built-in protection.

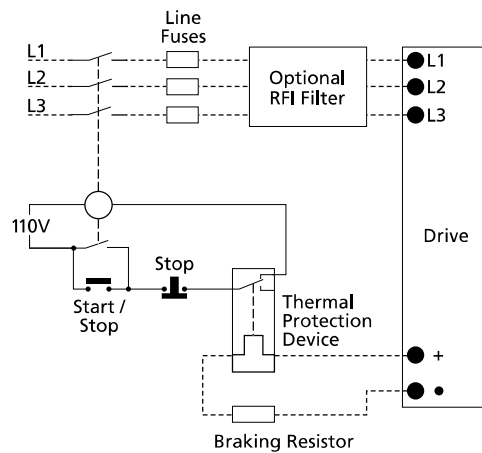

Cyclic Duty

The standard packages listed below are NEMA 1 rated and include built-in junction box, terminal strip, normally closed thermal contact (klixon switch) and resistors pre-wired with high-temperature Teflon wire.

These heavy-duty kits have been designed to provide dynamic braking for cyclic and continuous braking applications. There are three levels available: 10%, 25% and 50%. These levels refer to the continuous allowable braking level (i.e. 25% refers to 25% of rated motor braking torque) or the maximum allowable duty cycle rates with maximum specified "on-time" limitations (refer to illustration below).

$$\text{Duty Cycle} = \frac{\text{On Time } (\leq \text{max "on" time})}{\text{On Time} + \text{Off Time}}$$

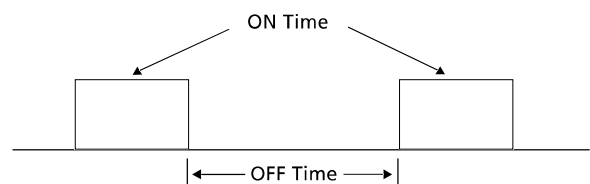

Dynamic Braking Resistors

Dynamic Braking Resistors - 230 Vac Galvanized NEMA 1 Enclosed

Drives	Heavy Duty HP	E-Stop Duty Panel Mounted No Thermostat		E-Stop Duty - NEMA 1 Normally Closed Thermostat		10% Duty Rated Normally Closed Thermostat		25% Duty Rated Normally Closed Thermostat		50% Duty Rated Normally Closed Thermostat	
		Order Code	Dims. H x W x D (in)	Order Code	Dims. H x W x D (in)	Order Code	Dims. H x W x D (in)	Order Code	Dims. H x W x D (in)	Order Code	Dims. H x W x D (in)
Maaa-01100017	0.33	DBR-1500-00300-P	10 x 3 x 3	DBR-1500-00300-ENC	5 x 14 x 4	DBR-1500-00300-ENC	5 x 14 x 4	DBR-1500-00300-ENC	5 x 14 x 4	DBR-1500-00300-ENC	5 x 14 x 4
Maaa-01100024	0.5	DBR-1500-00300-P	10 x 3 x 3	DBR-1500-00300-ENC	5 x 14 x 4	DBR-1500-00300-ENC	5 x 14 x 4	DBR-1500-00300-ENC	5 x 14 x 4	DBR-1500-00300-ENC	5 x 14 x 4
Maaa-02100042	1	DBR-1500-00300-P	10 x 3 x 3	DBR-1500-00300-ENC	5 x 14 x 4	DBR-1500-00300-ENC	5 x 14 x 4	DBR-1500-00300-ENC	5 x 14 x 4	DBR-1500-00600-ENC	5 x 14 x 4
Maaa-02100056	1.5	DBR-1500-00300-P	10 x 3 x 3	DBR-1500-00300-ENC	5 x 14 x 4	DBR-1500-00300-ENC	5 x 14 x 4	DBR-1500-00300-ENC	5 x 14 x 4	DBR-1500-00600-ENC	5 x 14 x 4
Maaa-01200017	0.33	DBR-1500-00300-P	10 x 3 x 3	DBR-1500-00300-ENC	5 x 14 x 4	DBR-1500-00300-ENC	5 x 14 x 4	DBR-1500-00300-ENC	5 x 14 x 4	DBR-1500-00300-ENC	5 x 14 x 4
Maaa-01200024	0.5	DBR-1500-00300-P	10 x 3 x 3	DBR-1500-00300-ENC	5 x 14 x 4	DBR-1500-00300-ENC	5 x 14 x 4	DBR-1500-00300-ENC	5 x 14 x 4	DBR-1500-00300-ENC	5 x 14 x 4
Maaa-01200033	0.75	DBR-1500-00300-P	10 x 3 x 3	DBR-1500-00300-ENC	5 x 14 x 4	DBR-1500-00300-ENC	5 x 14 x 4	DBR-1500-00300-ENC	5 x 14 x 4	DBR-1500-00300-ENC	5 x 14 x 4
Maaa-01200042	1	DBR-1500-00300-P	10 x 3 x 3	DBR-1500-00300-ENC	5 x 14 x 4	DBR-1500-00300-ENC	5 x 14 x 4	DBR-1500-00300-ENC	5 x 14 x 4	DBR-1500-00600-ENC	5 x 14 x 4
Maaa-02200024	0.5	DBR-0800-00300-P	10 x 3 x 3	DBR-0800-00300-ENC	5 x 14 x 4	DBR-0800-00300-ENC	5 x 14 x 4	DBR-0800-00300-ENC	5 x 14 x 4	DBR-0800-00300-ENC	5 x 14 x 4
Maaa-02200033	0.75	DBR-0800-00300-P	10 x 3 x 3	DBR-0800-00300-ENC	5 x 14 x 4	DBR-0800-00300-ENC	5 x 14 x 4	DBR-0800-00300-ENC	5 x 14 x 4	DBR-0800-00300-ENC	5 x 14 x 4
Maaa-02200042	1	DBR-0800-00300-P	10 x 3 x 3	DBR-0800-00300-ENC	5 x 14 x 4	DBR-0800-00300-ENC	5 x 14 x 4	DBR-0800-00300-ENC	5 x 14 x 4	DBR-0800-00600-ENC	5 x 14 x 4
Maaa-02200056	1.5	DBR-0800-00300-P	10 x 3 x 3	DBR-0800-00300-ENC	5 x 14 x 4	DBR-0800-00300-ENC	5 x 14 x 4	DBR-0800-00300-ENC	5 x 14 x 4	DBR-0800-00600-ENC	5 x 14 x 4
Maaa-02200075	2	DBR-0800-00300-P	10 x 3 x 3	DBR-0800-00300-ENC	5 x 14 x 4	DBR-0800-00300-ENC	5 x 14 x 4	DBR-0800-00600-ENC	5 x 14 x 7	DBR-0800-01500-ENC	5 x 14 x 13
Maaa-03200100	3	DBR-0800-00300-P	10 x 3 x 3	DBR-0800-00300-ENC	5 x 14 x 4	DBR-0500-00300-ENC	5 x 14 x 4	DBR-0500-01500-ENC	5 x 14 x 13	DBR-0500-01000-ENC	14 x 13 x 5
Maaa-04200133	3	DBR-0300-00400-P	12 x 3 x 1.5	DBR-0300-00400-ENC	5 x 14 x 4	DBR-0300-00600-ENC	5 x 14 x 7	DBR-0300-01500-ENC	5 x 14 x 4	DBR-0300-01500-ENC	5 x 14 x 4
Maaa-04200176	5	DBR-0300-00400-P	12 x 3 x 1.5	DBR-0200-00400-ENC	5 x 14 x 4	DBR-0200-00600-ENC	5 x 14 x 7	DBR-0200-01500-ENC	5 x 14 x 13	DBR-0200-03000-ENC	5 x 28 x 13
Mbbb-03200050	1	DBR-0500-00300-P	9 x 3 x 1.5	DBR-0500-00300-ENC	5 x 14 x 4	DBR-0500-00300-ENC	5 x 14 x 4	DBR-0500-00500-ENC	5 x 14 x 7	DBR-0500-01500-ENC	5 x 14 x 13
Mbbb-03200066	1.5	DBR-0500-00300-P	9 x 3 x 1.5	DBR-0500-00300-ENC	5 x 14 x 4	DBR-0500-00300-ENC	5 x 14 x 4	DBR-0500-00500-ENC	5 x 14 x 7	DBR-0500-01500-ENC	5 x 14 x 13
Mbbb-03200080	2	DBR-0500-00300-P	9 x 3 x 1.5	DBR-0500-00300-ENC	5 x 14 x 4	DBR-0500-00300-ENC	5 x 14 x 4	DBR-0500-00500-ENC	5 x 14 x 7	DBR-0500-01500-ENC	5 x 14 x 13
Mbbb-03200106	3	DBR-0500-00300-P	9 x 3 x 1.5	DBR-0400-00300-ENC	5 x 14 x 4	DBR-0400-00300-ENC	5 x 14 x 4	DBR-0400-00300-ENC	5 x 14 x 4	DBR-0350-01500-ENC	5 x 14 x 13
Mbbb-04200137	3	DBR-0300-00400-P	12 x 3 x 1.5	DBR-0200-00400-ENC	5 x 14 x 4	DBR-0200-00600-ENC	5 x 14 x 7	DBR-0200-01500-ENC	5 x 14 x 13	DBR-0200-01500-ENC	5 x 14 x 13
Mbbb-04200185	5	DBR-0300-00400-P	12 x 3 x 1.5	DBR-0200-00400-ENC	5 x 14 x 4	DBR-0200-00600-ENC	5 x 14 x 7	DBR-0200-01500-ENC	5 x 14 x 13	DBR-0200-03000-ENC	5 x 28 x 13
Mccc-05200250	7.5	DBR-0300-00400-P	12 x 3 x 1.5	DBR-0100-00600-ENC	5 x 14 x 4	DBR-0100-00900-ENC	5 x 14 x 10	DBR-0100-03000-ENC	5 x 21 x 13	DBR-0100-04500-ENC	5 x 28 x 13
Mccc-06200330	10			DBR-0100-00600-ENC	5 x 14 x 7	DBR-0100-01200-ENC	5 x 14 x 10	DBR-0100-03000-ENC	5 x 21 x 13	DBR-0100-06000-ENC	7 x 29 x 18
Mccc-06200440	15			DBR-0100-00600-ENC	5 x 14 x 7	DBR-0100-01200-ENC	5 x 14 x 10	DBR-0100-03000-ENC	5 x 21 x 13	DBR-0100-06000-ENC	7 x 29 x 18
Mccc-07200610	20			DBR-0055-02000-ENC	5 x 14 x 13	DBR-0055-02000-ENC	5 x 14 x 13	DBR-0055-04500-ENC	5 x 28 x 13	DBR-0055-09000-ENC	7 x 29 x 18
Mccc-07200750	25			DBR-0055-02000-ENC	5 x 14 x 13	DBR-0055-03000-ENC	5 x 21 x 13	DBR-0055-06000-ENC	7 x 29 x 18	DBR-0055-09000-ENC	7 x 29 x 18
Mccc-07200830	30			DBR-0055-02000-ENC	5 x 14 x 13	DBR-0055-03000-ENC	5 x 21 x 13	DBR-0055-06000-ENC	7 x 29 x 18	DBR-0055-12000-ENC	14 x 29 x 18
Mccc-08201160	40			DBR-0055-02000-ENC	5 x 14 x 13	DBR-0055-03000-ENC	5 x 21 x 13	DBR-0055-09000-ENC	7 x 29 x 18	DBR-0055-18000-ENC	14 x 29 x 18
Mccc-08201320	50			DBR-0055-02000-ENC	5 x 14 x 13	DBR-0055-04500-ENC	5 x 28 x 13	DBR-0055-12000-ENC	14 x 29 x 18	DBR-0055-18000-ENC	14 x 29 x 18
Mddd-09201760	60			DBR-0016-03000-ENC	5 x 21 x 10	DBR-0016-06000-ENC	5 x 28 x 13	DBR-0016-12000-ENC	16 x 29 x 18	DBR-0016-21000-ENC	23 x 29 x 18
Mddd-09202190	75			DBR-0016-03000-ENC	5 x 21 x 10	DBR-0016-06000-ENC	5 x 28 x 13	DBR-0016-15000-ENC	16 x 29 x 18	DBR-0016-27000-ENC	37 x 29 x 18
Meee-10202830	100			DBR-0022-05500-ENC	5 x 28 x 13	DBR-0022-12000-ENC	9 x 29 x 18	DBR-0022-21000-ENC	23 x 29 x 18	DBR-0022-48000-ENC	37 x 29 x 18
Meee-10203000	125			DBR-0022-05500-ENC	5 x 28 x 13	DBR-0022-12000-ENC	16 x 29 x 18	DBR-0022-27000-ENC	23 x 29 x 18	DBR-0022-48000-ENC	36 x 29 x 28

aaa = Unidrive M100, M101, M200, M201, M300, H530, M400
 bbb = Unidrive M600, M700, M701, M702, H570, H571, H572
 ccc = Unidrive M200, M201, M300, M400, M600, M700, M701, M702, H570, H571, H572
 ddd = Unidrive M200, M201, M300, M400, M600, M700, M701, M702
 eee = Unidrive M600, M700, M701, M702

Example: DBR-0400-00500-ENC is a 40.0 Ohm, 500 W Resistor, E = NEMA 1 Enclosure and NC = Normally Closed Thermostat
 Standard resistor assemblies are not UL recognized. Consult factory for UL versions.

Dynamic Braking Resistors

Dynamic Braking Resistors - 460 Vac Galvanized NEMA 1 Enclosed

Drives	Heavy Duty HP	E-Stop Duty Panel Mounted No Thermostat		E-Stop Duty - NEMA 1 Normally Closed Thermostat		10% Duty Rated Normally Closed Thermostat		25% Duty Rated Normally Closed Thermostat		50% Duty Rated Normally Closed Thermostat	
		Order Code	Dims. H x W x D (in)	Order Code	Dims. H x W x D (in)	Order Code	Dims. H x W x D (in)	Order Code	Dims. H x W x D (in)	Order Code	Dims. H x W x D (in)
Maaa-02400013	0.5	DBR-3000-00300-P	10 x 3 x 3	DBR-3000-00300-ENC	5 x 14 x 4	DBR-3000-00300-ENC	5 x 14 x 4	DBR-3000-00300-ENC	5 x 14 x 4	DBR-3000-00300-ENC	5 x 14 x 4
Maaa-02400018	0.75	DBR-3000-00300-P	10 x 3 x 3	DBR-3000-00300-ENC	5 x 14 x 4	DBR-3000-00300-ENC	5 x 14 x 4	DBR-3000-00300-ENC	5 x 14 x 4	DBR-3000-00300-ENC	5 x 14 x 4
Maaa-02400023	1	DBR-3000-00300-P	10 x 3 x 3	DBR-3000-00300-ENC	5 x 14 x 4	DBR-3000-00300-ENC	5 x 14 x 4	DBR-3000-00300-ENC	5 x 14 x 4	DBR-3000-00800-ENC	5 x 14 x 10
Maaa-02400032	1.5	DBR-3000-00300-P	10 x 3 x 3	DBR-3000-00300-ENC	5 x 14 x 4	DBR-3000-00300-ENC	5 x 14 x 4	DBR-3000-00300-ENC	5 x 14 x 4	DBR-3000-00800-ENC	5 x 14 x 10
Maaa-02400041	2	DBR-3000-00300-P	10 x 3 x 3	DBR-3000-00300-ENC	5 x 14 x 4	DBR-3000-00300-ENC	5 x 14 x 4	DBR-3000-00800-ENC	5 x 14 x 10	DBR-3000-00800-ENC	5 x 14 x 10
Maaa-03400056	3	DBR-1200-00300-P	9 x 3 x 1.5	DBR-1200-00300-ENC	5 x 14 x 4	DBR-1200-00300-ENC	5 x 14 x 4	DBR-1200-01500-ENC	5 x 14 x 13	DBR-1200-01500-ENC	5 x 14 x 13
Maaa-03400073	3	DBR-1200-00300-P	9 x 3 x 1.5	DBR-1200-00300-ENC	5 x 14 x 4	DBR-1200-00300-ENC	5 x 14 x 4	DBR-1200-01500-ENC	5 x 14 x 13	DBR-1200-01500-ENC	5 x 14 x 13
Maaa-03400094	5	DBR-1200-00300-P	9 x 3 x 1.5	DBR-1200-00800-ENC	5 x 14 x 7	DBR-1200-00800-ENC	5 x 14 x 7	DBR-1200-01500-ENC	5 x 14 x 13	DBR-1200-03000-ENC	5 x 13 x 21.1
Maaa-04400135	7.5	DBR-0600-00400-P	12 x 3 x 1.5	DBR-0600-00400-ENC	5 x 14 x 4	DBR-0600-01000-ENC	5 x 14 x 10	DBR-0600-01500-ENC	5 x 14 x 13	DBR-0600-03000-ENC	5 x 28 x 13
Maaa-04400170	10	DBR-0600-00400-P	12 x 3 x 1.5	DBR-0600-00400-ENC	5 x 14 x 4	DBR-0600-01000-ENC	5 x 14 x 10	DBR-0600-03000-ENC	5 x 28 x 13	DBR-0600-04500-ENC	7 x 29 x 18
Mbbb-03400025	1	DBR-0800-00300-P	10 x 3 x 3	DBR-0800-00300-ENC	5 x 14 x 4	DBR-0800-00300-ENC	5 x 14 x 4	DBR-0800-00600-ENC	5 x 14 x 7	DBR-0800-00600-ENC	5 x 14 x 7
Mbbb-03400031	1.5	DBR-0800-00300-P	10 x 3 x 3	DBR-0800-00300-ENC	5 x 14 x 4	DBR-0800-00300-ENC	5 x 14 x 4	DBR-0800-00600-ENC	5 x 14 x 7	DBR-0800-00600-ENC	5 x 14 x 7
Mbbb-03400045	2	DBR-0800-00300-P	10 x 3 x 3	DBR-0800-00300-ENC	5 x 14 x 4	DBR-0800-00300-ENC	5 x 14 x 4	DBR-0800-00600-ENC	5 x 14 x 7	DBR-0800-01500-ENC	5 x 14 x 13
Mbbb-03400062	3	DBR-0800-00300-P	10 x 3 x 3	DBR-0800-00300-ENC	5 x 14 x 4	DBR-0800-00300-ENC	5 x 14 x 4	DBR-0800-01500-ENC	5 x 14 x 13	DBR-0800-01500-ENC	5 x 14 x 13
Mbbb-03400068	5	DBR-0600-00400-P	12 x 3 x 1.5	DBR-0600-00400-ENC	5 x 14 x 4	DBR-0600-00600-ENC	5 x 14 x 7	DBR-0600-01500-ENC	5 x 14 x 13	DBR-0600-01500-ENC	5 x 14 x 13
Mbbb-03400100	5	DBR-0600-00400-P	12 x 3 x 1.5	DBR-0600-00400-ENC	5 x 14 x 4	DBR-0600-00600-ENC	5 x 14 x 7	DBR-0600-01500-ENC	5 x 14 x 13	DBR-0600-03000-ENC	5 x 28 x 13
Mbbb-04400150	10			DBR-0400-00500-ENC	5 x 14 x 7	DBR-0400-01000-ENC	5 x 14 x 10	DBR-0400-01500-ENC	5 x 14 x 13	DBR-0400-03000-ENC	5 x 21 x 13
Mbbb-04400172	10			DBR-0400-00500-ENC	5 x 14 x 7	DBR-0400-01000-ENC	5 x 14 x 10	DBR-0400-03000-ENC	5 x 21 x 13	DBR-0400-04500-ENC	5 x 28 x 13
Mccc-05400270	20			DBR-0400-01000-ENC	5 x 14 x 10	DBR-0400-01500-ENC	5 x 14 x 13	DBR-0400-03000-ENC	5 x 21 x 13	DBR-0400-06000-ENC	9 x 28 x 18
Mccc-05400300	20			DBR-0240-01500-ENC	5 x 14 x 13	DBR-0240-01500-ENC	5 x 14 x 13	DBR-0240-04500-ENC	7 x 29 x 18	DBR-0240-09000-ENC	7 x 29 x 18
Mccc-06400350	25			DBR-0200-01500-ENC	5 x 14 x 13	DBR-0200-01500-ENC	5 x 14 x 13	DBR-0200-04500-ENC	7 x 29 x 18	DBR-0200-09000-ENC	7 x 29 x 18
Mccc-06400420	30			DBR-0200-01500-ENC	5 x 14 x 13	DBR-0200-03000-ENC	5 x 28 x 13	DBR-0200-06000-ENC	7 x 29 x 18	DBR-0200-09000-ENC	7 x 29 x 18
Mccc-06400470	30			DBR-0200-01500-ENC	5 x 14 x 13	DBR-0200-03000-ENC	5 x 28 x 13	DBR-0200-06000-ENC	7 x 29 x 18	DBR-0200-12000-ENC	14 x 29 x 18
Mccc-07400660	50			DBR-0120-03000-ENC	5 x 21 x 13	DBR-0120-03000-ENC	5 x 21 x 13	DBR-0120-09000-ENC	7 x 29 x 18	DBR-0120-18000-ENC	14 x 29 x 18
Mccc-07400770	60			DBR-0120-03000-ENC	5 x 21 x 13	DBR-0120-03000-ENC	5 x 28 x 13	DBR-0120-12000-ENC	14 x 29 x 18	DBR-0120-18000-ENC	14 x 29 x 18
Mccc-07401000	75			DBR-0100-03000-ENC	5 x 21 x 13	DBR-0100-06000-ENC	7 x 29 x 18	DBR-0100-12000-ENC	14 x 29 x 18	DBR-0100-24000-ENC	14 x 29 x 18
Mccc-08401340	100			DBR-0100-04500-ENC	5 x 28 x 13	DBR-0100-06000-ENC	7 x 29 x 18	DBR-0100-18000-ENC	14 x 29 x 18	DBR-0100-36000-ENC	21 x 29 x 18
Mccc-08401570	125			DBR-0100-06000-ENC	7 x 29 x 18	DBR-0100-09000-ENC	7 x 29 x 18	DBR-0100-24000-ENC	14 x 29 x 18	DBR-0100-36000-ENC	21 x 29 x 18
Mddd-09402000	150			DBR-0055-06000-ENC	7 x 29 x 18	DBR-0055-12000-ENC	14 x 29 x 18	DBR-0055-24000-ENC	14 x 29 x 18	DBR-0055-50000-ENC	28 x 29 x 18
Mddd-09402240	150			DBR-0055-09000-ENC	7 x 29 x 18	DBR-0055-12000-ENC	14 x 29 x 18	DBR-0055-24000-ENC	14 x 29 x 18	DBR-0055-50000-ENC	28 x 29 x 18
Meee-10402700	200			DBR-0055-12000-ENC	14 x 29 x 18	DBR-0055-18000-ENC	14 x 29 x 18	DBR-0055-36000-ENC	21 x 29 x 18	DBR-0055-60000-ENC	35 x 29 x 18
Meee-10403200	250			DBR-0055-12000-ENC	14 x 29 x 18	DBR-0055-24000-ENC	14 x 29 x 18				
Meee-11403770	300			DBR-0022-18000-ENC	16 x 29 x 18	DBR-0022-18000-ENC	16 x 29 x 18				
Meee-11404170	350			DBR-0022-12000-ENC	16 x 29 x 18	DBR-0022-21000-ENC	30 x 29 x 18				
Meee-11404640	400			DBR-0016-15000-ENC	16 x 29 x 18	DBR-0016-27000-ENC	37 x 29 x 18				
											N/A

aaa = Unidrive M100, M101, M200, M201, M300, H530, M400
 bbb = Unidrive M600, M700, M701, M702, H570, H571, H572
 ccc = Unidrive M200, M201, M300, M400, M600, M700, M701, M702, H570, H571, H572
 ddd = Unidrive M200, M201, M300, M400, M600, M700, M701, M702
 eee = Unidrive M600, M700, M701, M702

Example: DBR-0400-00500-ENC is a 40.0 Ohm, 500 W Resistor, E = NEMA 1 Enclosure and NC = Normally Closed Thermostat
 Standard resistor assemblies are not UL recognized. Consult factory for UL versions.

Dynamic Braking Resistors

Dynamic Braking Resistors - 575 Vac

Galvanized NEMA 1 Enclosed

Drives	Heavy Duty HP	E-Stop Duty - NEMA 1 Normally Closed Thermostat		10% Duty Rated Normally Closed Thermostat		25% Duty Rated Normally Closed Thermostat		50% Duty Rated Normally Closed Thermostat	
		Order Code	Dims. H x W x D (in)	Order Code	Dims. H x W x D (in)	Order Code	Dims. H x W x D (in)	Order Code	Dims. H x W x D (in)
Mccc-05500030	2	DBR-1200-00300-ENC	5 x 14 x 4	DBR-1200-00300-ENC	5 x 14 x 4	DBR-1200-00800-ENC	5 x 14 x 7	DBR-1200-00800-ENC	5 x 14 x 7
Mccc-05500040	3	DBR-1200-00300-ENC	5 x 14 x 4	DBR-1200-00300-ENC	5 x 14 x 4	DBR-1200-00800-ENC	5 x 14 x 7	DBR-1200-01500-ENC	5 x 14 x 13
Mccc-05500069	5	DBR-1200-00300-ENC	5 x 14 x 4	DBR-1200-00800-ENC	5 x 14 x 7	DBR-1200-01500-ENC	5 x 14 x 13	DBR-1200-01500-ENC	5 x 14 x 13
Mccc-06500100	7.5	DBR-0800-00300-ENC	5 x 14 x 4	DBR-0800-00600-ENC	5 x 14 x 7	DBR-0800-01500-ENC	5 x 14 x 13	DBR-0600-03000-ENC	5 x 28 x 13
Mccc-06500150	10	DBR-0600-00400-ENC	5 x 14 x 4	DBR-0600-01500-ENC	5 x 14 x 13	DBR-0600-03000-ENC	5 x 28 x 13	DBR-0400-04500-ENC	5 x 28 x 13
Mccc-06500190	15	DBR-0400-00500-ENC	5 x 14 x 7	DBR-0400-01500-ENC	5 x 14 x 13	DBR-0400-03000-ENC	5 x 21 x 13	DBR-0400-06000-ENC	9 x 28 x 18
Mccc-06500230	20	DBR-0200-01500-ENC	5 x 14 x 13	DBR-0200-01500-ENC	5 x 14 x 13	DBR-0200-04500-ENC	7 x 29 x 18	DBR-0200-09000-ENC	7 x 29 x 18
Mccc-06500290	25	DBR-0200-01500-ENC	5 x 14 x 13	DBR-0200-03000-ENC	5 x 28 x 13	DBR-0200-04500-ENC	7 x 29 x 18	DBR-0200-09000-ENC	7 x 29 x 18
Mccc-06500350	30	DBR-0150-01500-ENC	5 x 14 x 13	DBR-0150-03000-ENC	5 x 21 x 13	DBR-0150-06000-ENC	7 x 29 x 18	DBR-0150-12000-ENC	14 x 29 x 18
Mccc-07500440	40	DBR-0150-01500-ENC	5 x 14 x 13	DBR-0150-03000-ENC	5 x 21 x 13	DBR-0150-06000-ENC	7 x 29 x 18	DBR-0150-12000-ENC	14 x 29 x 18
Mccc-07500550	50	DBR-0150-03000-ENC	5 x 21 x 13	DBR-0150-03000-ENC	5 x 21 x 13	DBR-0150-09000-ENC	7 x 29 x 18	DBR-0150-18000-ENC	14 x 29 x 18
Mccc-08500630	60	DBR-0150-03000-ENC	5 x 21 x 13	DBR-0150-04500-ENC	5 x 28 x 13	DBR-0150-12000-ENC	14 x 29 x 18	DBR-0150-18000-ENC	14 x 29 x 18
Mccc-08500860	75	DBR-0150-03000-ENC	5 x 21 x 13	DBR-0150-06000-ENC	7 x 29 x 18	DBR-0150-12000-ENC	14 x 29 x 18	DBR-0150-24000-ENC	21 x 29 x 18
Mddd-09501040	100	DBR-0120-04500-ENC	5 x 28 x 13	DBR-0120-06000-ENC	7 x 29 x 18	DBR-0120-18000-ENC	14 x 29 x 18	DBR-0120-36000-ENC	21 x 29 x 18
Mddd-09501310	125	DBR-0120-04500-ENC	5 x 28 x 13	DBR-0120-09000-ENC	7 x 29 x 18	DBR-0120-24000-ENC	14 x 29 x 18	DBR-0120-36000-ENC	21 x 29 x 18
Meee-10501520	150	DBR-0055-06000-ENC	7 x 29 x 18	DBR-0055-12000-ENC	14 x 29 x 18				
Meee-10501900	200	DBR-0055-06000-ENC	7 x 29 x 18	DBR-0055-18000-ENC	14 x 29 x 18				
Meee-11502000	200	DBR-0022-12000-ENC	16 x 29 x 18	DBR-0022-21000-ENC	30 x 29 x 18			N/A	
Meee-11502540	250	DBR-0022-12000-ENC	16 x 29 x 18	DBR-0022-21000-ENC	30 x 29 x 18				
Meee-11502850	300	DBR-0022-12000-ENC	16 x 29 x 18	DBR-0022-27000-ENC	37 x 29 x 18				

ccc = Unidrive M200, M201, M300, M400, M600, M700, M701, M702, HS70, HS71, HS72
ddd = Unidrive M200, M201, M300, M400, M600, M700, M701, M702
eee = Unidrive M600, M700, M701, M702

Example: DBR-0200-00600-ENC is a 20.0 Ohm, 600 W Resistor,
E = NEMA 1 Enclosure and NC = Normally Closed Thermostat
Standard resistor assemblies are not UL recognized.
Consult factory for UL versions.

Dynamic Braking Resistors

UL Recognized

Description	UL Recognized Continuous 100%	Order Code	Dimensions H x W x D (in)			Weight (lbs)	
300 W, 20 Ohm	250W	1220-0003020	2.4	8.5	1.2	1.5	
300 W, 50 Ohm		1220-0003050	2.4	8.5	1.2	1.5	
300 W, 68 Ohm		1220-0003068	2.4	8.5	1.2	1.5	
300 W, 80 Ohm		1220-0003080	2.4	8.5	1.2	1.5	
300 W, 100 Ohm		1220-0003100	2.4	8.5	1.2	1.5	
300 W, 135 Ohm		1220-0003135	2.4	8.5	1.2	1.5	
300 W, 270 Ohm		1220-0003270	2.4	8.5	1.2	1.5	
500 W, 20 Ohm		400W	1220-0005020	2.4	13.3	1.2	2.4
500 W, 50 Ohm	1220-0005050		2.4	13.3	1.2	2.4	
500 W, 68 Ohm	1220-0005068		2.4	13.3	1.2	2.4	
500 W, 80 Ohm	1220-0005080		2.4	13.3	1.2	2.4	
500 W, 100 Ohm	1220-0005100		2.4	13.3	1.2	2.4	
500 W, 270 Ohm	1220-0005270		2.4	13.3	1.2	2.4	
1000 W, 20 Ohm	500W		1220-0010020	5.6	14.3	4.9	4.0
1000 W, 40 Ohm			1220-0010040	5.6	14.3	4.9	4.0
1000 W, 50 Ohm		1220-0010050	5.6	14.3	4.9	4.0	
1000 W, 80 Ohm		1220-0010080	5.6	14.3	4.9	4.0	
1000 W, 100 Ohm		1220-0010100	5.6	14.3	4.9	4.0	
1500 W, 20 Ohm		1125W	1220-0015020	5.6	17.3	4.9	4.9
1500 W, 40 Ohm			1220-0015040	5.6	17.3	4.9	4.9
1500 W, 50 Ohm			1220-0015050	5.6	17.3	4.9	4.9
1500 W, 100 Ohm	1220-0015100		5.6	17.3	4.9	4.9	
2000 W, 20 Ohm	1700W	1220-0020020	5.6	14.3	7.3	6.6	
2000 W, 40 Ohm		1220-0020040	5.6	14.3	7.3	6.6	
2000 W, 50 Ohm		1220-0020050	5.6	14.3	7.3	6.6	
2000 W, 100 Ohm		1220-0020100	5.6	14.3	7.3	6.6	
4500 W, 9 Ohm	2250W	1220-0045009	5.6	17.3	12.2	11.9	
4500 W, 20 Ohm		1220-0045020	5.6	17.3	12.2	11.9	
4500 W, 40 Ohm		1220-0045040	5.6	17.3	12.2	11.9	
6000 W, 9 Ohm	3000W	1220-0060009	5.6	17.3	14.6	15.4	
6000 W, 20 Ohm		1220-0060020	5.6	17.3	14.6	15.4	
6000 W, 40 Ohm		1220-0060040	5.6	17.3	14.6	15.4	